

Gas Industry Standard

GIS/E59:2006

Specification for

**Foam plug flow stop devices for LP and MP gas mains
and services**

Cadent
Your Gas Network

Northern
Gas Networks 

 **SGN**
Your gas. Our network.

 **WALES&WEST**
UTILITIES

Contents

	Page
Foreword	iii
Mandatory and non-mandatory requirements	iii
Disclaimer	iii
Brief history	iv
1 Scope	1
2 Normative references	1
3 Terms and definitions	1
4 Construction and materials	1
5 Design	1
6 Performance	3
7 Quality and user instructions	4
8 Marking	5
Annex A (normative) Pneumatic leak test	6
Annex B (normative) End load test	14
Annex C (normative) Secondary restraint end load test	16
Annex D (normative) Pipe wall strain during FPFS device deployment	18
Annex E (normative) Environmental testing	21
Figure A.1 — Test rig for hydraulic proof test	10
Figure A.2 — Set up prior to FPFS device insertion	11
Figure A.3 — FPFS device insertion and curing	12
Figure A.4 — FPFS device pneumatic test	13
Figure B.1 — FPFS device axial pull test	15
Figure C.1 — Support arm axial pull test	17
Figure D.1 — Pipe sample with strain gauge	20
Table 1 — Maximum permitted mains working pressures for FPFS device	2
Table 2 — Maximum permissible leakage rates for the FPFS device	3
Table 3 — Axial loads to be applied to FPFS device and support arm	4
Table A.1 — FPFS device and pipe sizes	7
Table A.2 — Hydraulic proof pressures	7
Table A.3 — Pneumatic pipe pressures for FPFS device foaming operations	8

Foreword

Gas Industry Standards (GIS) are revised, when necessary, by the issue of new editions. Users should ensure that they are in possession of the latest edition. Contractors and other users external to Gas Transporters should direct their requests for copies of a GIS to the department or group responsible for the initial issue of their contract documentation.

Comments and queries regarding the technical content of this document should be directed in the first instance to the contract department of the Gas Transporter responsible for the initial issue of their contract documentation.

This standard calls for the use of procedures that may be injurious to health if adequate precautions are not taken. It refers only to technical suitability and does not absolve the user from legal obligations relating to health and safety at any stage.

Compliance with this engineering document does not confer immunity from prosecution for breach of statutory or other legal obligations.

Mandatory and non-mandatory requirements

For the purposes of a GIS the following auxiliary verbs have the meanings indicated:

- can** indicates a physical possibility;
- may** indicates an option that is not mandatory;
- shall** indicates a GIS requirement;
- should** indicates best practice and is the preferred option. If an alternative method is used then a suitable and sufficient risk assessment needs to be completed to show that the alternative method delivers the same, or better, level of protection.

Disclaimer

This engineering document is provided for use by Gas Transporters and such of their contractors as are obliged by the terms of their contracts to comply with this engineering document. Where this engineering document is used by any other party, it is the responsibility of that party to ensure that the engineering document is correctly applied.

Brief history

First published as T/SP/E/59 Editorial update to comply with GRM Edited by BSI in accordance with BS 0-3:1997 Reviewed on behalf of the Gas Distribution Networks' Technical Standard Forum by BSI Reviewed by TSF	September 2004 August 2006 September 2013 June 2018
---	--

© Energy Networks Association on behalf of Cadent Gas Limited, Northern Gas Networks, SGN and Wales & West Utilities Ltd.

This Gas Industry Standard is copyright and must not be reproduced in whole or in part by any means without the approval in writing of Energy Networks Association.

1 Scope

This Gas Industry Standard specifies requirements for primary and secondary foam plug flow stop devices. These devices are intended for use when abandoning low pressure (LP) and medium pressure (MP) gas mains and services.

The field of application covers gas services in the size range 19 mm ($\frac{3}{4}$ in) to 63 mm ($2\frac{1}{2}$ in), services and mains in the size range from 75 mm (3 in) to 900 mm (36 in) operating at pressures up to 2 bar with reduced mains operating pressures for the deployment of the foam plug flow stop devices in the size range 300 mm (12 in) to 900 mm (36 in).

2 Normative references

The following referenced documents are indispensable for the application of this document. For dated references, only the edition cited applies. For undated references, the latest edition of the referenced document (including any amendments) applies.

BS 1600, *Specification for dimensions of steel pipe for the petroleum industry*.

3 Terms and definitions

For the purposes of this standard the following terms and definitions apply.

3.1

low pressure (LP)

operating pressures not greater than 75 mbar

3.2

medium pressure (MP)

operating pressures greater than 75 mbar but not greater than 2 bar

3.3

safety factor

ratio of the actual working pressure to the maximum pressure that the item can operate at

4 Construction and materials

All materials shall meet appropriate standards, and these shall be identified by the manufacturer. A list of these standards shall be available for inspection by the gas transporter or its approved agent. The material shall meet these standards at the end of the stated shelf life. All performance tests shall be carried out using material that it is at the end of its specified shelf life.

5 Design

5.1 The design of the FPFS (foam plug flow stop) device shall enable it to be deployed into a gas main under live gas conditions, at normal working pressures. Maximum permitted working pressures shall be in accordance with Table 1. The size of the FPFS device shall be matched to the size of main that is to be flow stopped.

Table 1 — Maximum permitted mains working pressures for FPFS device

FPFS device size		Maximum pressure
mm	(in)	bar
19	($\frac{3}{4}$)	2.00
25	(1)	2.00
32	(1 $\frac{1}{4}$)	2.00
38	(1 $\frac{1}{2}$)	2.00
50	(2)	2.00
63	(2 $\frac{1}{2}$)	2.00
75	(3)	2.00
100	(4)	2.00
150	(6)	2.00
200	(8)	2.00
300	(12)	1.00
450	(18)	0.34
600	(24)	0.14
900	(36)	0.05

5.2 The maximum permitted leakage rates past the FPFS device shall be in accordance with Table 2.

5.3 For mains in the size range 75 mm to 900 mm:

- a) a secondary restraint system shall be fitted to prevent any axial movement of the FPFS device;
- b) the design of the secondary restraint system shall be capable of retaining the full pressure taken by the FPFS device;
- c) the FPFS device shall have sufficient strength to resist the gas pressures when being restrained only by the secondary restraint system.

5.4 The FPFS device shall be so designed to ensure that unacceptable levels of hoop strain (≥ 30 microstrain) are not produced in the gas main.

5.5 The design of the FPFS device and its secondary restraint system shall have a safety factor of 3 against maximum applied gas pressures.

Any associated equipment used to deploy the FPFS device shall have a safety factor of 3 against the maximum applied gas pressures in the main that is to be flow stopped.

6 Performance

6.1 General

If the same materials are used for the construction of each FPFS devices, and the same grade of foam is used then the following size range of FPFS devices shall be tested.

- a) *FPFS for mains*: 200 mm, 300 mm, 600 mm and 900 mm diameter;

NOTE 1 This will cover the range from 75 mm to 900 mm diameter.

- b) *FPFS for services*: 19 mm, 32 mm and 50 mm diameter.

NOTE 2 This will cover the range from 19 mm to 63 mm diameter .

6.2 Pneumatic leak test

The maximum permitted working pressure for each size of FPFS device shall be in accordance with Table 1. The maximum leakage rate for each size of FPFS device, at the maximum permitted working pressure, shall be in accordance with Table 2. When tested in accordance with Annex A, the maximum leakage rate of three samples of each size of FPFS device shall be in accordance with Table 2.

Table 2 — Maximum permissible leakage rates for the FPFS device

Pipe size		Maximum pressure	Maximum acceptable leakage rate
mm	(in)	bar	L/min
19	($\frac{3}{4}$)	2.00	100
25	(1)	2.00	100
32	(1 $\frac{1}{4}$)	2.00	100
38	(1 $\frac{1}{2}$)	2.00	100
50	(2)	2.00	100
63	(2 $\frac{1}{2}$)	2.00	100
75	(3)	2.00	100
100	(4)	2.00	100
150	(6)	2.00	100
200	(8)	2.00	133
300	(12)	1.00	183
450	(18)	0.34	200
600	(24)	0.14	250
900	(36)	0.05	250

6.3 End load test

When tested in accordance with Annex B the FPFS device shall withstand the axial end loads specified in Table 3 for 30 min without any structural failure or gross movement in excess of 5 mm.

Table 3 — Axial loads to be applied to FPFS device and support arm

Pipe size mm	Pipe size (in)	Axial load for 30 min tonne
75	(3)	0.3
100	(4)	0.5
150	(6)	1.1
200	(8)	1.9
300	(12)	2.2
450	(18)	1.7
600	(24)	1.2
900	(36)	1.0

6.4 Secondary restraint system test

When tested in accordance with Annex C the secondary restraint system shall withstand the axial end loads specified in Table 3 for 30 min without any structural failure or gross movement in excess of 5 mm.

NOTE It is not necessary to use a secondary restraint system for FPFS devices below 75 mm (3 in).

6.5 Induced pipe wall hoop strain

When tested in accordance with Annex D the deployment of a FPFS device shall not produce a strain of more than 30 microstrain in the hoop direction of a section of main.

NOTE It is not necessary to measure pipe wall hoop strain on FPFS devices below 75 mm (3 in).

6.6 Environmental requirements

The performance of the FPFS device shall not be affected by contaminants likely to be encountered in the field. When tested in accordance with Annex E the pressure drop of the three contaminated samples shall not be greater than 5 % of the pressure drop test of the control sample.

7 Quality and user instructions

User instructions shall be provided with each item of equipment.

8 Marking

Identification of the FPFS device size shall be clearly marked on the device. Products conforming to GIS/E59 shall also be permanently marked with the following information:

- a) the number and date of this standard, i.e GIS/E59:2006 ¹⁾;
- b) the name or trademark of the manufacturer or their appointed agent;
- c) the manufacturer's contact details;
- d) production date;
- e) Production batch identification number;
- f) model and serial number;
- g) where authorized, the product conformity mark of a third party certification body, e.g. BSI Kitemark;

NOTE Attention is drawn to the advantages of using third party certification of conformance to a standard.

- h) maximum working pressure;
- i) use by date;
- j) summary instructions for use and any hazard notification.

¹⁾ Marking GIS/E59:2006 on or in relation to a product represents a manufacturer's declaration of conformity, i.e. a claim by or on behalf of the manufacturer that the product meets the requirements of the standard. The accuracy of the claim is therefore solely the responsibility of the person making the claim. Such a declaration is not to be confused with third party certification of conformity, which may also be desirable.

Annex A (normative)

Pneumatic leak test

A.1 Principle

The leaktightness of the FPFS device is determined when subjected to pneumatic test pressures.

A.2 Apparatus

A.2.1 *Pressure gauge*, capable of measuring up to 2.5 bar in steps of 1 mbar.

A.2.2 *Pressure relief valve*, capable of being set at 2.1 bar.

A.2.3 *End cap*, to suit pipe (2 off).

A.2.4 *1 in steel pipework*, to make pressure connections conforming to BS 1600.

A.2.5 *1 in BSP valve*, (2 off).

A.2.6 *End cap retaining system*, which could comprise steel tie rods and steel beams to suit.

A.2.7 *Pneumatic pressure source*, set at 2 bar.

A.2.8 *Hydraulic pressure source*, at 3 bar.

A.2.9 *General light oil*.

A.2.10 *Flow meter*, capable of measuring between 20 L/min and 400 L/min.

A.2.11 *Steel pipe*, conforming to BS 1600 for containing the FPFS device.

A.3 Test sample

For each size of FPFS device to be qualified, test three pipe samples of the appropriate diameter for leakage under a pneumatic test pressure. The device shall also include the secondary support system.

A.4 Procedure

A.4.1 For each size of FPFS device to be qualified, test three pipe samples of the appropriate diameter for leakage under a pneumatic test pressure. The length of each sample shall be 1.5 m. Steel pipe shall conform to BS 1600. FPFS device and pipe combination shall be in accordance with Table A.1.

A.4.2 Prior to the insertion of the FPFS device into a section of pipe for pneumatic leak testing, hydraulically proof test the pipe and end cap arrangement to the appropriate value specified in Table A.2.

NOTE This is a level of 1.5 times the maximum pneumatic pressure to be applied.

Set up the test rig in accordance with Figure A.1.

Table A.1 — FPFS device and pipe sizes

FPFS device size		Pipe outside diameter
mm	(in)	mm
19	($\frac{3}{4}$)	26
25	(1)	33
32	(1 $\frac{1}{4}$)	42
38	(1 $\frac{1}{2}$)	48
50	(2)	60
63	(2 $\frac{1}{2}$)	73
75	(3)	89
100	(4)	114
150	(6)	168
200	(8)	219
300	(12)	324
450	(18)	457
600	(24)	610
900	(36)	914

Table A.2 — Hydraulic proof pressures

Pipe size		Hydraulic pressure
mm	(in)	bar
19	($\frac{3}{4}$)	3.00
25	(1)	3.00
32	(1 $\frac{1}{4}$)	3.00
38	(1 $\frac{1}{2}$)	3.00
50	(2)	3.00
63	(2 $\frac{1}{2}$)	3.00
75	(3)	3.00
100	(4)	3.00
150	(6)	3.00
200	(8)	3.00
300	(12)	3.00
450	(18)	1.02
600	(24)	0.42
900	(36)	0.15

A.4.3 For each pipe sample, drill and tap all of the access holes in the pipe that are required for the FPFS device insertion equipment and support arm. Also drill two holes for pressure relief during FPFS device foaming. For one of the pipes in each sample a strain gauge shall be bonded to the pipe and connected to measure the strain in the hoop direction on the pipe at the mid point that will be influenced by the expanding FPFS device.

Prepare each of the three pipe samples as follows:

- a) Degrease the new pipe sample and swab the bore with general light oil.
- b) Fit the end caps and the end cap restraint system. Connect the FPFS device insertion equipment and support arm to the pipe. Connect manual pressure relief system. The pressure relief valve shall be set to 1.2 times the maximum test pressure. Set up in accordance with Figure A.2.
- c) Raise pressure in pipe to the level specified in Table A.3. Check the pipe sample for leaks. During the foaming off of one of each of the FPFS device sizes the hoop strain shall be monitored to determine if there is a significant change.

Table A.3 — Pneumatic pipe pressures for FPFS device foaming operations

Pipe size		Pneumatic pressure
mm	(in)	bar
19	($\frac{3}{4}$)	2.00
25	(1)	2.00
32	($1\frac{1}{4}$)	2.00
38	($1\frac{1}{2}$)	2.00
50	(2)	2.00
63	($2\frac{1}{2}$)	2.00
75	(3)	2.00
100	(4)	2.00
150	(6)	2.00
200	(8)	2.00
300	(2)	1.00
450	(18)	0.34
600	(24)	0.14
900	(36)	0.05

A.4.4 Condition pipe to $5\text{ }^{\circ}\text{C} \pm 2\text{ }^{\circ}\text{C}$ for a period of 24 h. Condition the foam between $5\text{ }^{\circ}\text{C}$ and $30\text{ }^{\circ}\text{C}$ for a period of 24 h. Insert the FPFS device into pipe according to manufacturer's instructions and insert FPFS device support arm. Inject foam into FPFS device pipe according to manufacturer's instructions and monitor pipe internal pressure. Manually relieve the pressure in the pipe to ensure that it does not deviate by more than $\pm 5\%$ from the pressures specified in Table A.3. Refer to Figure A.3.

A.4.5 Allow the FPFS device to cure in accordance with manufacturer's instructions and then depressurize the pipe. Remove the manual pressure relief system and the pressure relief valve. Connect the pipe on support arm side of the FPFS device to a flow meter and a pressurization port to the pipe on the other side of the FPFS device in accordance with Figure A.4.

A.4.6 Apply the test pressure for a period of 24 h and monitor the leakage rate during this period.

A.5 Expression of results

Record and report the following:

- a) the hydraulic test pressure (bar);
- b) the ambient temperature at the start of the pneumatic test pressure (°C);
- c) the pneumatic test pressure at start of the test and after 24 h period (bar);
- d) the flow rate past the FPFS device at start of the test and after 24 h period (L/min).

A.6 Test report

The test report shall include the following information:

- a) reference to this standard, i.e. GIS/E59;
- b) the results of the determination;
- c) any additional factors which may have affected the results of the test.

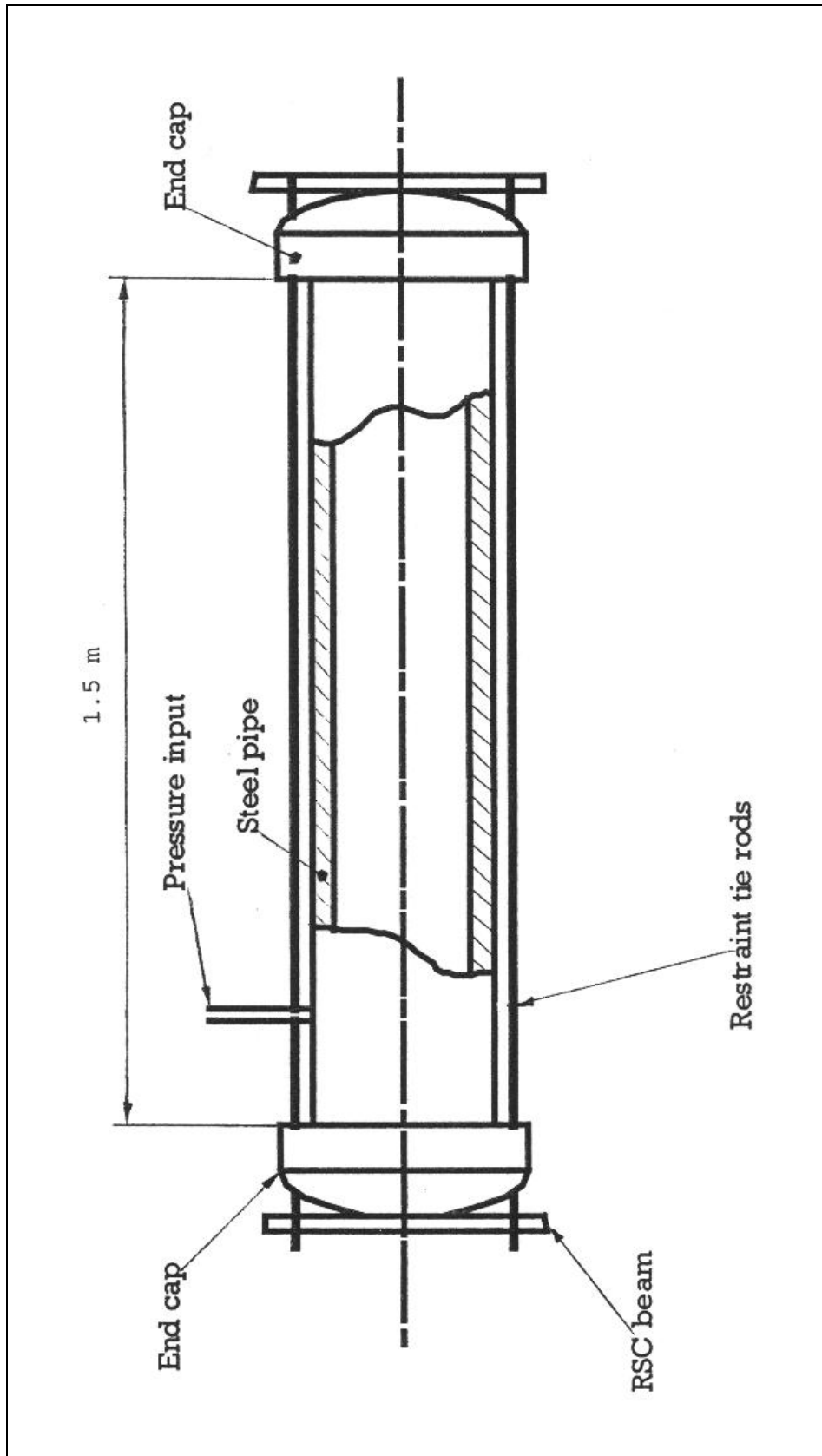

Figure A.1 — Test rig for hydraulic proof test

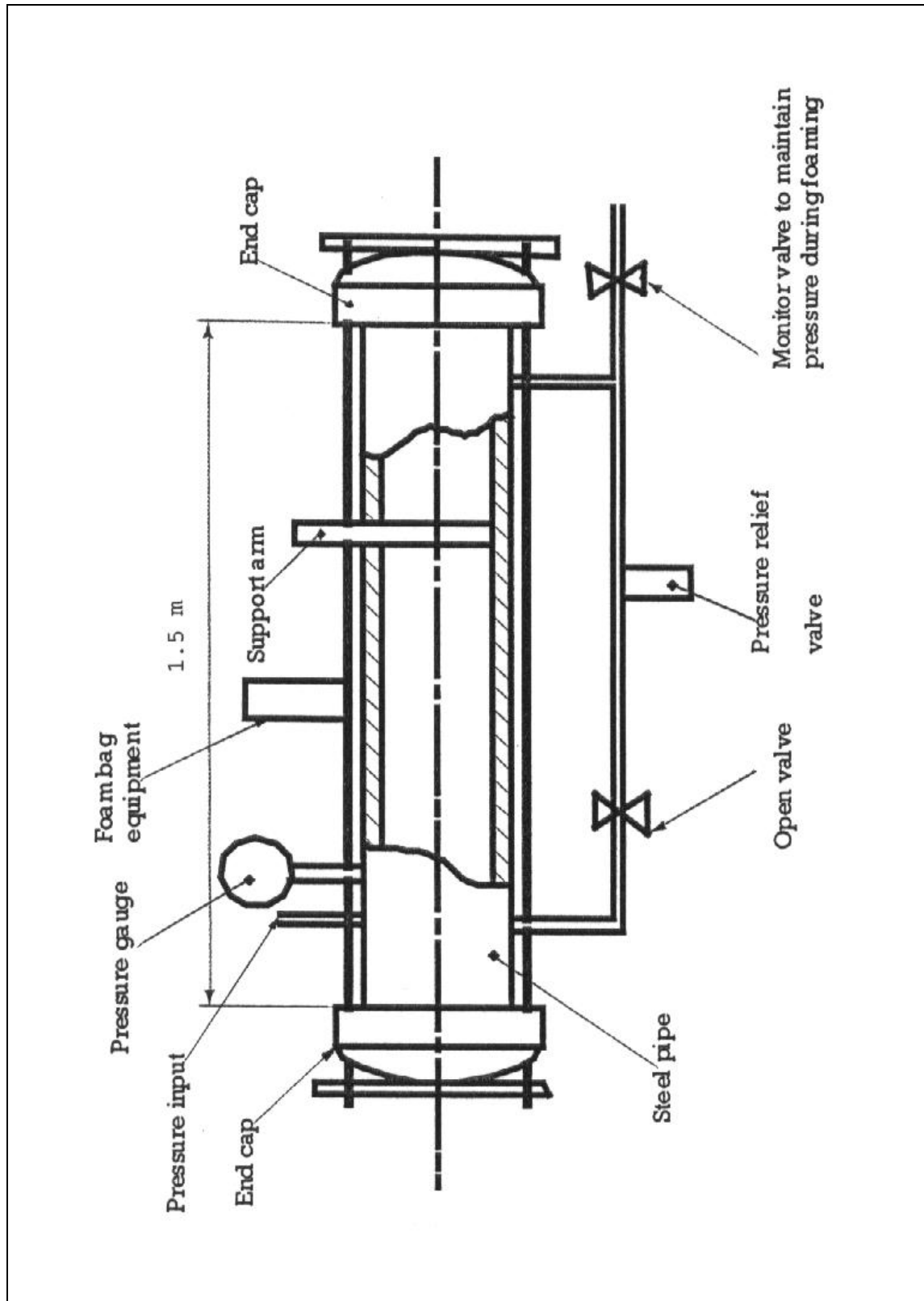

Figure A.2 — Set up prior to FPFS device insertion

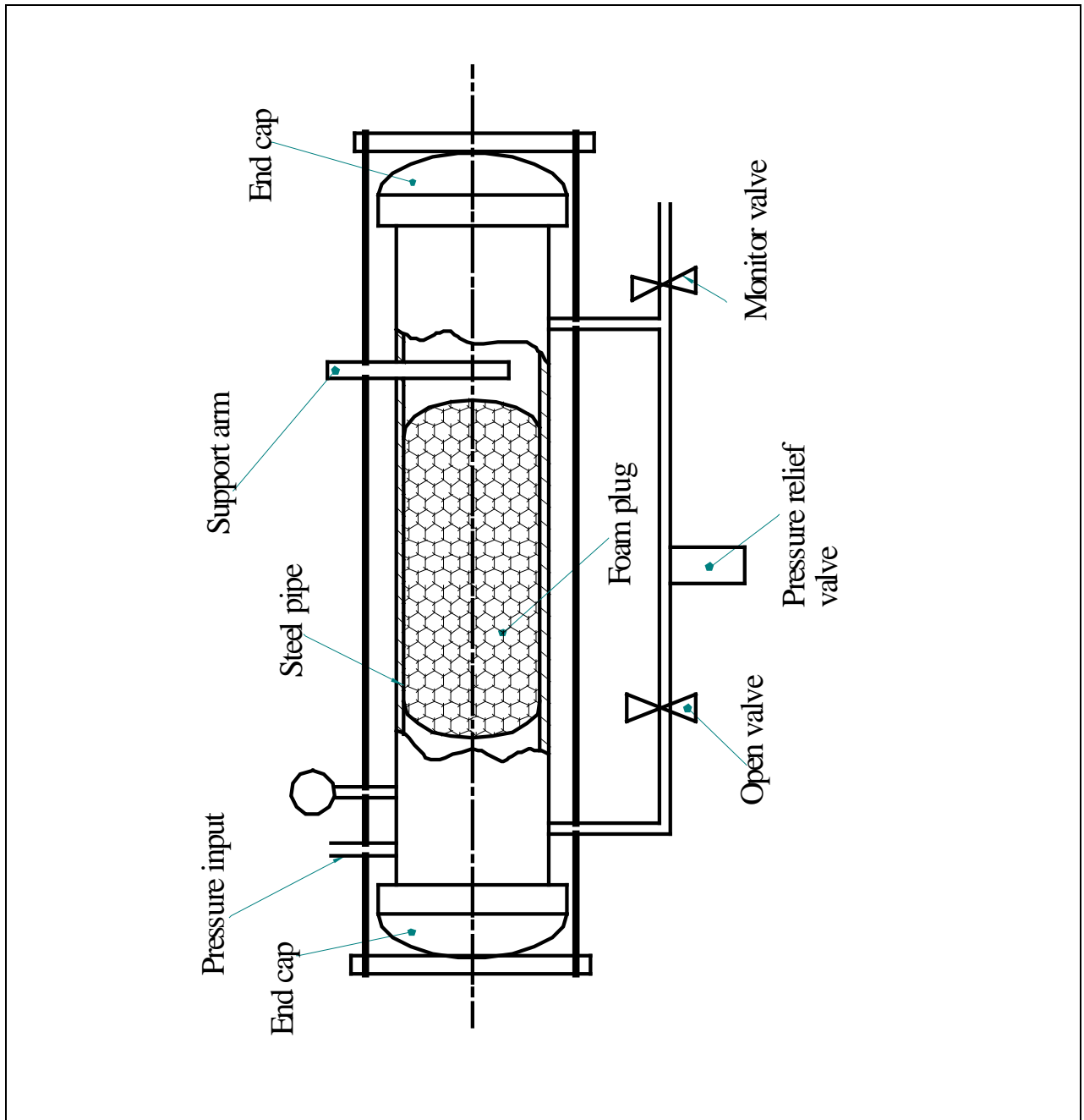

Figure A.3 — PFPS device insertion and curing

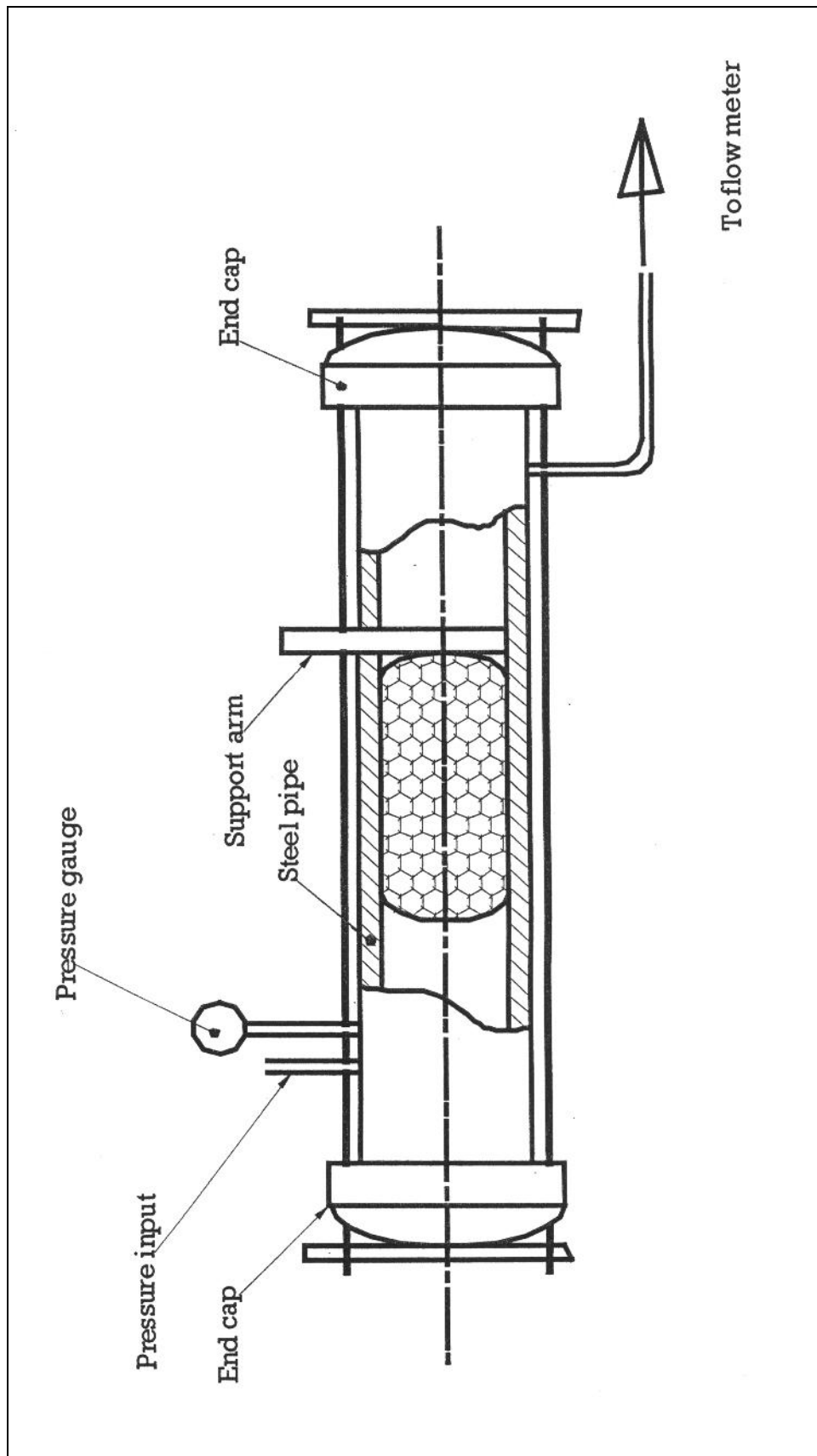

Figure A.4 — PFPS device pneumatic test

Annex B (normative)

End load test

B.1 Principle

The ability of the FPFS device to withstand axial end loads generated from the pressure loading is determined.

B.2 Apparatus

B.2.1 Test sample (re-used), as used in Annex A and re-configured as shown in Figure B.1.

B.2.2 *Load cell*, capable of measuring up to 2.5 tonne in steps of 0.01 tonne.

B.2.3 *Equipment*, capable of applying a load of up to 2.5 tonne on the FPFS device.

B.3 Test sample

For each size of FPFS device to be qualified, test three pipe samples of the appropriate diameter for the axial load test.

B.4 Procedure

Use the test samples that have been previously used for the pneumatic leak test.

Remove the end caps from the pipe and provide a means for the foam bag to be end loaded; a typical arrangement is shown in Figure B.1. Measure distance between the FPFS device and the end of the pipe and note this figure. Insert a device for measuring any axial movement of the FPFS device. Refer to Figure B.1.

Subject each sample to the appropriate test load specified in Table 3. Hold the load for a 30 min period. Movement of FPFS device shall be monitored during loading.

B.5 Expression of results

Record and report the following:

- a) the applied axial load at start of the test (tonne);
- b) the applied axial load at start of the test (tonne) after 30 min;
- c) axial movement of the FPFS device after 30 min.

B.6 Test report

The test report shall include the following information:

- a) reference to this standard, i.e. GIS/E59;
- b) the results of the determination;
- c) any additional factors which may have affected the results of the test.

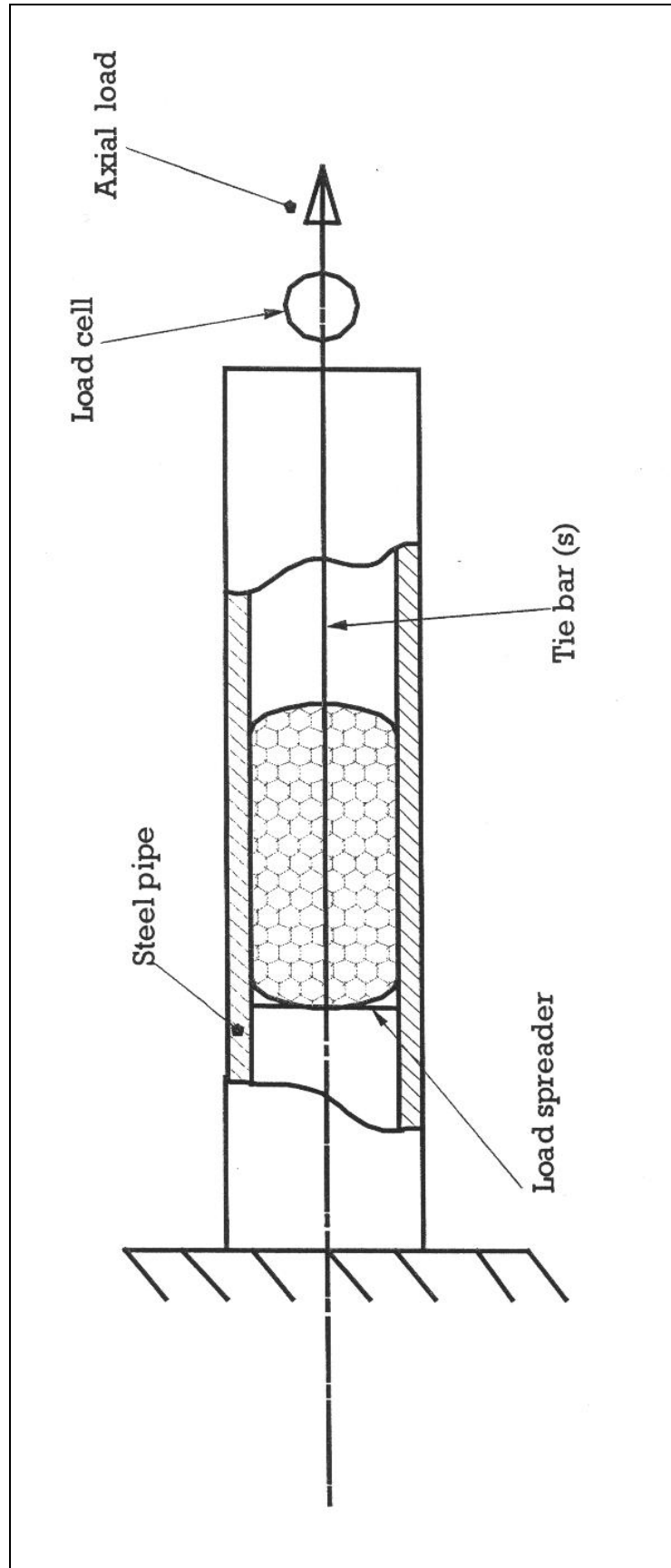

Figure B.1 — FPFS device axial pull test

Annex C (normative)

Secondary restraint end load test

C.1 Principle

The ability of the secondary restraint system to withstand axial end loads is determined.

C.2 Apparatus

C.2.1 *Test sample (re-used)*, as used in Annex B and re-configured as shown in Figure C.1.

C.2.2 *Load cell*, capable of measuring up to 2.5 tonne in steps of 0.01 tonne.

C.2.3 *Equipment*, capable of applying a load of up to 2.5 tonne on the FPFS device.

C.3 Test sample

For each size of FPFS device to be qualified, test one pipe sample of the appropriate diameter for the secondary restraint axial load test.

C.4 Procedure

Set up the secondary restraint system for the particular size to be tested as shown in Figure C.1. It shall only be necessary to test a single secondary restraint system for each size of FPFS device to be qualified. Apply the relevant test load specified in Table 3 and hold for a period of 30 min.

NOTE This test is not required for FPFS devices below 75 mm (3 in) diameter.

C.5 Expression of results

Record and report the following:

- a) the applied axial load at start of the test (tonne);
- b) the applied axial load at start of the test (tonne) after 30 min;
- c) axial movement of the secondary restraint system after 30 min.

C.6 Test report

The test report shall include the following information:

- a) reference to this standard, i.e. GIS/E59;
- b) the results of the determination;
- c) any additional factors which may have affected the results of the test.

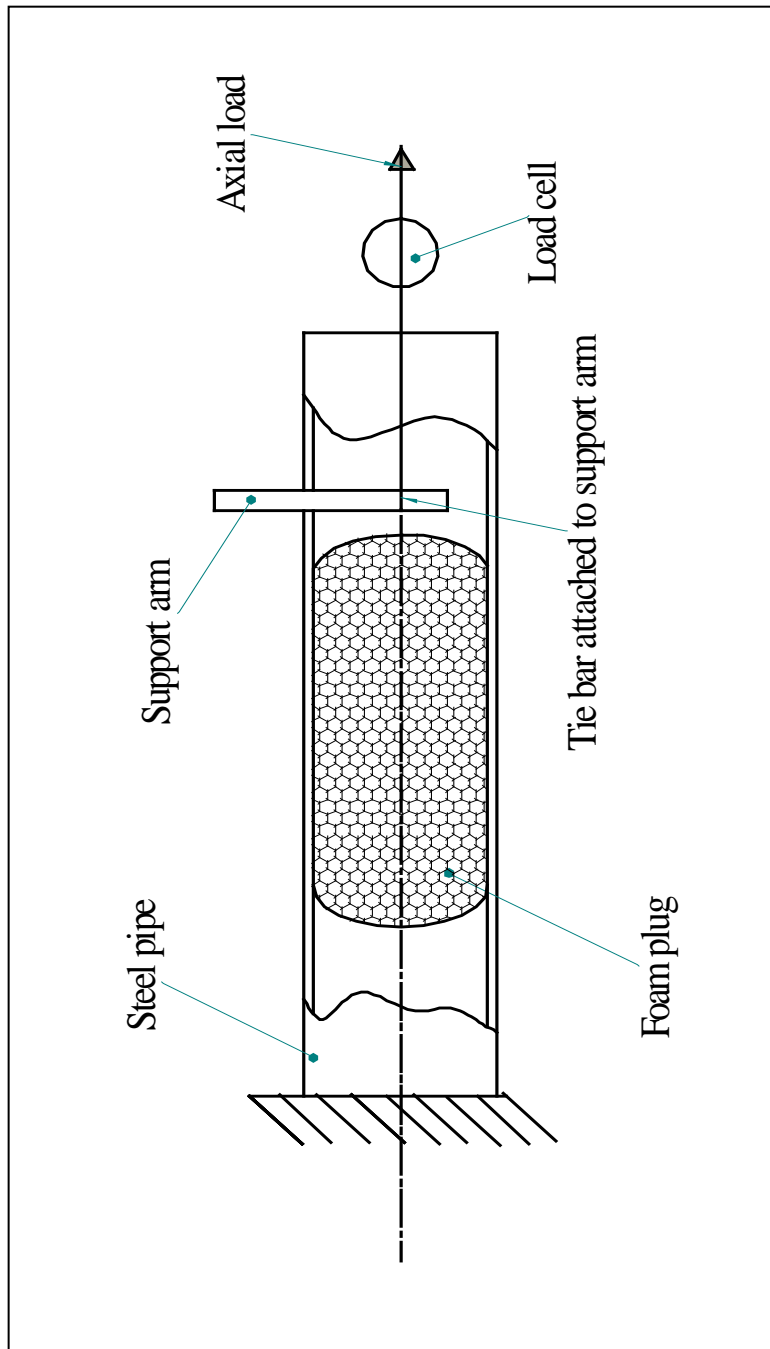

Figure C.1 — Support arm axial pull test

Annex D (normative)**Pipe wall strain during FPFS device deployment****D.1 Principle**

The pipe wall hoop strain produced by the deployment of the FPFS device is determined.

D.2 Apparatus

D.2.1 *Strain gauge and strain gauge measuring equipment*, set up in accordance with Annex A.

D.3 Test sample

Carry out test using a single sample of steel pipe for each size of FPFS device to be qualified.

D.4 Procedure

Wall strain during FPFS device deployment use a strain gauge on a single sample of steel pipe for each size of FPFS device to be qualified in accordance with Figure D.1.

The strain gauge shall be fitted in accordance with the manufacturer's instructions.

The gauge and measurement system shall be calibrated in accordance with the manufacturer's instructions.

Deploy the FPFS device in accordance with Annex A.

Monitor the resulting strain when the FPFS device is deployed.

D.5 Expression of results

D.5.1 Record and report the following:

- a) the strain level before deployment of the FPFS device (micro-strain);
- b) the maximum strain level after deployment of the FPFS device (micro-strain).

D.5.2 Having established the maximum pipe wall strain for the steel sample, calculate the equivalent internal pressure P required to generate this strain from the following equation:

$$P = \frac{20tE\varepsilon}{D}$$

where:

- P is the equivalent pressure newtons per square millimetre (N/mm²);
- T is the steel pipe wall thickness in millimetres (mm);
- E is the Young's modulus for steel pipe in newtons per square millimetre (N/mm²);
- ε is the steel pipe wall microstrain;
- D is the inner diameter of steel pipe in millimetres (mm).

D.5.3 Having established the internal pipe sample pressure, calculate the hoop strain that would be generated in a section of a gas main constructed from a particular material from the following equation:

$$\varepsilon_{\text{main}} = \frac{PD_{\text{main}}}{20 t_{\text{main}} E_{\text{main}}}$$

where:

D_{main} is the diameter of gas main in millimetres (mm);

t_{main} is the thickness of gas main in millimetres (mm);

E_{main} is Youngs modulus for gas main newtons per square millimetre (N/mm²);

D.5.4 Determine the strain calculated in a particular type of main.

D.6 Test report

The test report shall include the following information:

- a) reference to this standard, i.e. GIS/E59;
- b) the results of the determination;
- c) any additional factors which may have affected the results of the test.

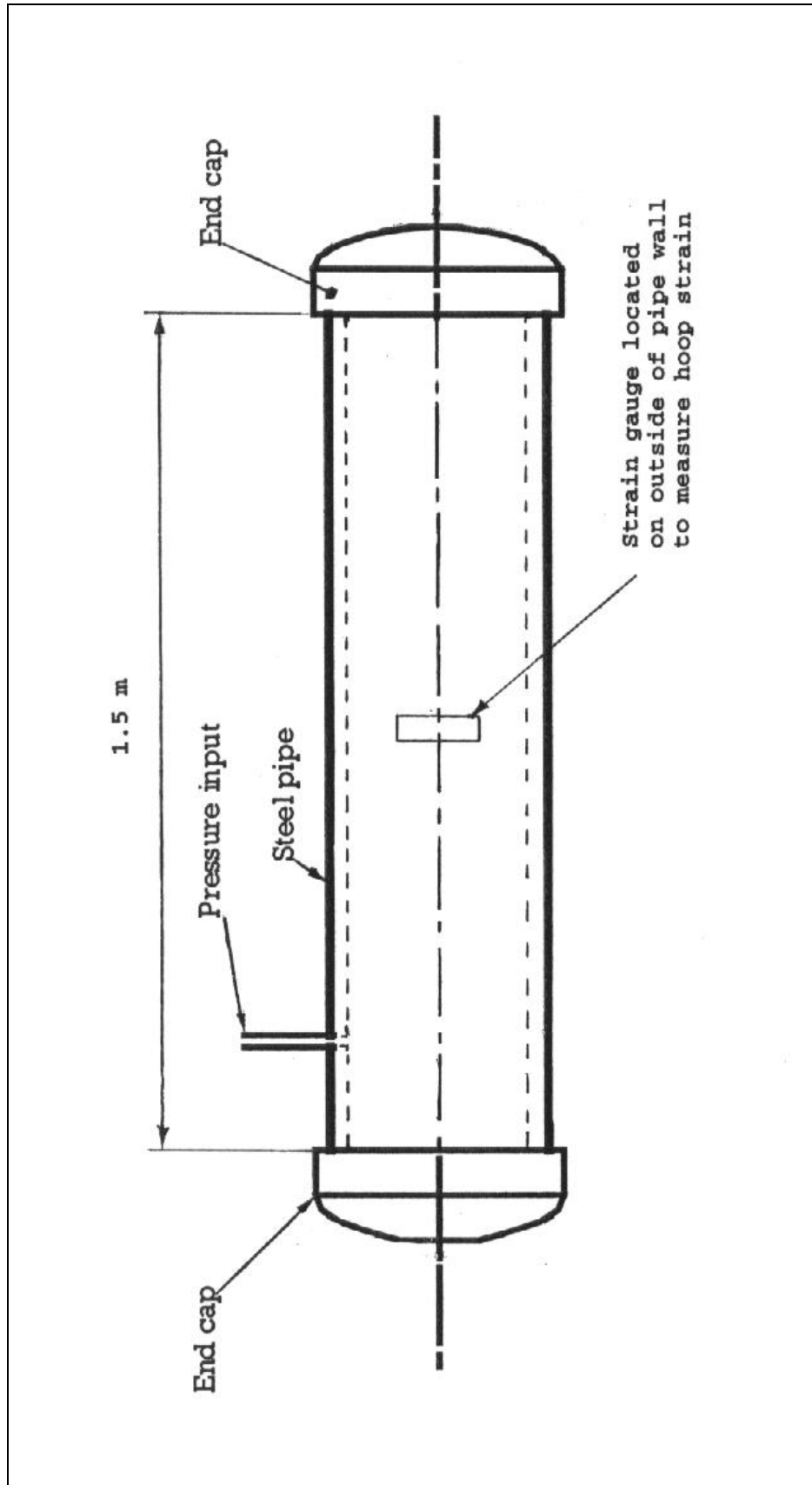

Figure D.1 — Pipe sample with strain gauge

Annex E (normative)

Environmental testing

E.1 Principle

The ability of the FPFS device to withstand contamination is determined.

E.2 Apparatus

E.2.1 *Test set up*, in accordance with Annex A, in particular see Figure A.2.

NOTE It is not necessary to include the support arm.

E.2.2 *Monoethylene glycol*.

E.2.3 *Diethylene glycol*.

E.2.4 *Distillate*.

E.3 Test sample

Carry out the test using a single size of FPFS device for each contaminant together with an uncontaminated control sample; pipe samples shall be chosen from Table A.1 and shall be either 100 mm (4 in), 150 mm (6 in) or 200 mm (8 in) diameter.

E.4 Procedure

E.4.1 Test a single size of FPFS device for the environmental test. Pipe samples shall be chosen from Table A.1 and shall be either 100 mm (4 in), 150 mm (6 in) or 200 mm (8 in) diameter.

Prepare three samples of pipe by immersing one pipe sample in each of the following contaminants:

- a) monoethylene glycol;
- b) diethylene glycol;
- c) distillate.

A fourth pipe sample shall remain uncontaminated.

E.4.2 Deploy a FPFS device into each of the four samples in accordance with the manufacturer's instructions and allow to cure. It shall not be necessary to deploy any secondary restraint mechanism. Subject each of the four test samples to a pressure drop test of 2 bar over a 24 h period. Set up the test in accordance with Figure A.4.

E.4.3 If no leakage is detected then increase the pressure to 3 bar and retest for leakage.

E.5 Expression of results

Record and report the following:

- a) pressure drop at start of test (mbar) with source pressure at 2 bar;
- b) pressure drop after 24 h from start of test (mbar) with source pressure at 2 bar;
- c) pressure drop after 24 h from start of test (mbar) with source pressure at 3 bar.

E.6 Test report

The test report shall include the following information:

- a) reference to this standard, i.e. GIS/E59;
- b) the results of the determination;
- c) any additional factors which may have affected the results of the test.